

**HEAT TRACE**

***FREEZSTOP***  
***MICRO SYSTEM***

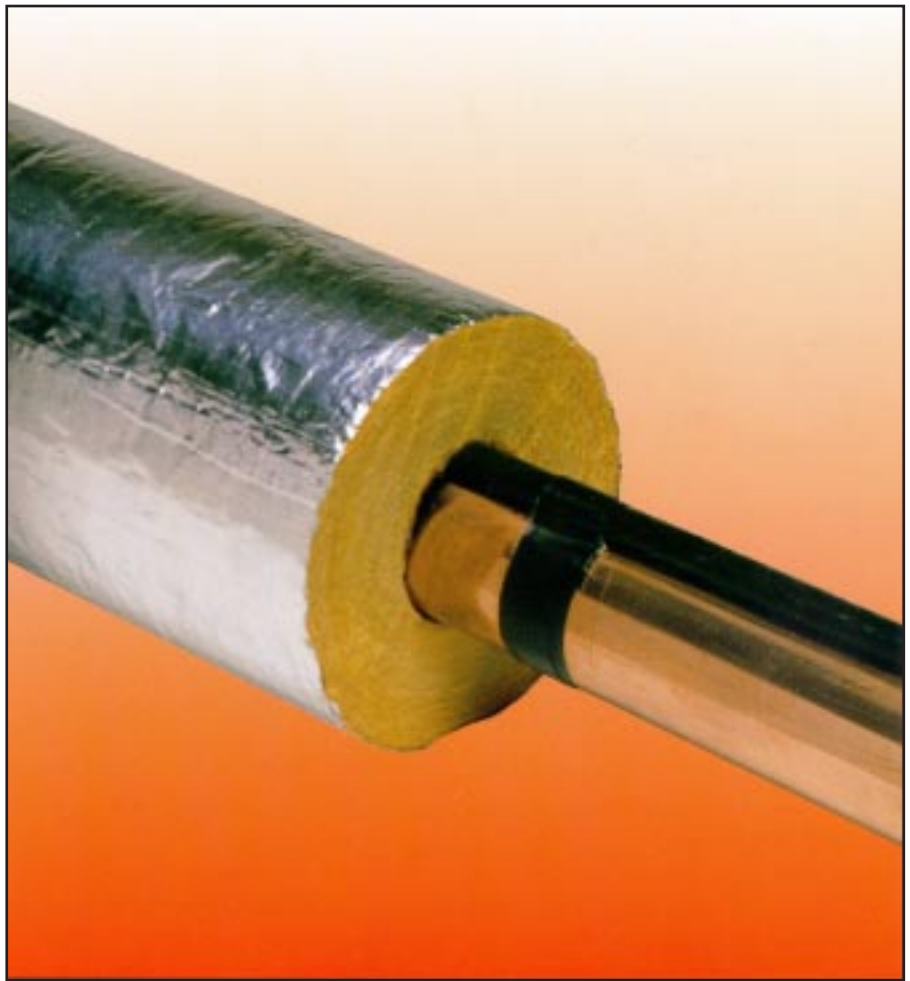

*Freeze Protection of Pipework*

# Prevent Burst or Blocked Pipes

## The Problem

Thermal insulation alone will not prevent freezing of pipes. For example, a 3/4" pipe having 25mm thick insulation will freeze solid in only 13 hours when the ambient temperature is at - 10 °C.

Frozen water pipes burst causing loss of supply, flooding and damage. Fuel lines can block causing heater failure. Freezstop Micro from Heat Trace eliminates these problems safely, and efficiently.

## The Solution

The Freezstop Micro system was developed for use on almost all pipes - metallic and plastic. *Plastic pipes must be foiled over the heater run.* It prevents hot and cold water pipes from freezing, fuel oil lines and pipes containing other fluids or chemicals from clogging or crystallising.

## Safe, Efficient, Reliable

Freezstop Micro is a self-regulating heating cable especially developed for this application. The self-regulating effect causes the cable to generate progressively more heat as the pipe cools down, and less heat as the temperature rises. Thus, it tends to energy efficiency and can never overheat or burnout - even when overlapped.

The Freezstop Micro system is therefore temperature safe, energy efficient and reliable. It operates automatically and requires virtually no maintenance.

## Complete System

The Freezstop Micro system comprises the Freezstop Micro heating cable, together with an installer friendly Uni-Clip connection system, an optional frost thermostat / contactor unit, distribution board and all component parts to provide a comprehensive system. System design and installation is easy – even for inexperienced electricians.

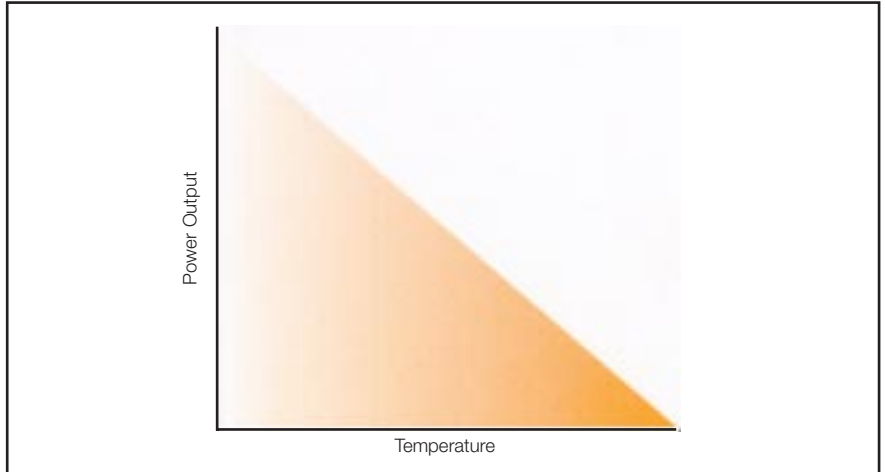
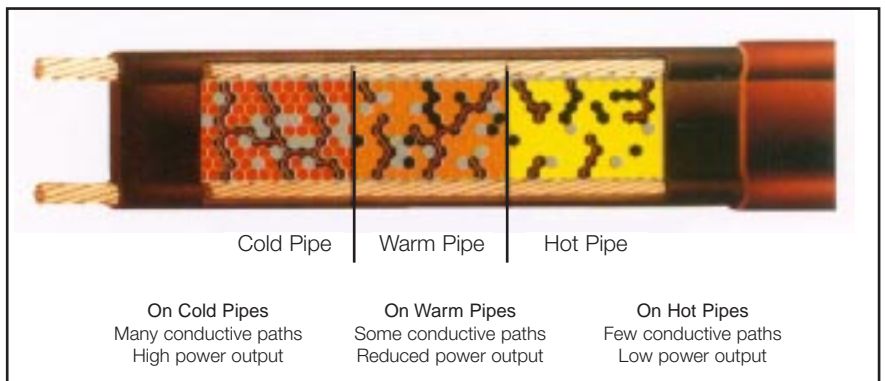

## Design Guide

A Freezstop Micro system can be designed in 4 steps.

STEP 1 - Determine heating cable type and thermal insulation thickness

STEP 2 - Calculate heating cable length required.

STEP 3 - Determine the number of heating circuits / distribution board requirements

STEP 4 - Define the number of system components needed.

### STEP 1

Selection of Heating Cable Type and Thermal Insulation Thickness

The following Tables match heating cable type with thermal insulation thickness required to maintain pipes at +5°C for different minimum ambient temperatures and pipe sizes.

Calculation basis for Tables:

- Decimal numbers indicate heating cable spiralled to pipe, (spiral ratio)  
eg. 1.3 = 1.3m of heater / m of pipe. Whole numbers mean straight traced cables.
- 2 means 2 cables straight traced.
- 11 = Heating Cable Cat Ref 11FSM2-CT  
17 = Heating Cable Cat Ref 17FSM2-CT
- Supply voltage 230V
- Insulation k-factor 0.037W/mK maximum. ie., materials such as phenolic foam, glass fibre, mineral wool, polyurethane foam are suitable.

For conditions other than as stated, consult your local Heat Trace Ltd Representative.

**FOR MINIMUM AMBIENT TEMPERATURES  
DOWN TO -30°C**

Key - Steel Pipes  
Plastic Pipes

Pipe Size	Insulation Thickness				
	9	20	25	40	50
½"	1 x 17 <b>1.2 x 17</b>	1 x 11 <b>1.1 x 17</b>	1 x 11 <b>1 x 11</b>	1 x 11 <b>1 x 11</b>	1 x 11 <b>1 x 11</b>
¾"	1.1 x 17 <b>1.5 x 17</b>	1 x 11 <b>1.3 x 17</b>	1 x 11 <b>1.1 x 17</b>	1 x 11 <b>1 x 11</b>	1 x 11 <b>1 x 11</b>
1"	1.3 x 17 -	1 x 17 <b>1.5 x 17</b>	1 x 11 <b>1.3 x 17</b>	1 x 11 <b>1 x 11</b>	1 x 11 <b>1 x 11</b>
1¼"	2 x 17 -	1 x 17 <b>2 x 17</b>	1 x 17 <b>1.5 x 17</b>	1 x 11 <b>1.2 x 17</b>	1 x 11 <b>1 x 11</b>
1½"	2 x 17 -	1 x 17 <b>1.3 x 17</b>	1 x 17 <b>1.1 x 17</b>	1 x 11 <b>1.3 x 17</b>	1 x 11 <b>1.1 x 17</b>
2"	-	1 x 17 <b>1.5 x 17</b>	1 x 17 <b>1.3 x 17</b>	1 x 17 <b>1.5 x 17</b>	1 x 11 <b>1.2 x 17</b>
2½"	-	1.3 x 17 -	1.1 x 17 <b>1.5 x 17</b>	1 x 17 <b>1.1 x 17</b>	1 x 17 <b>1.4 x 17</b>
3"	-	2 x 17 -	1.3 x 17 -	1 x 17 <b>1.2 x 17</b>	1 x 17 <b>1.1 x 17</b>
4"	-	2 x 17 -	2 x 17 -	1.1 x 17 <b>1.5 x 17</b>	1 x 17 <b>1.3 x 17</b>
6"	-	-	-	1.5 x 17 -	1.3 x 17 <b>2 x 17</b>
8"	-	-	-	-	-
10"	-	-	-	-	-

**FOR MINIMUM AMBIENT TEMPERATURES  
DOWN TO -15°C**

Key - Steel Pipes  
Plastic Pipes

Pipe Size	Insulation Thickness				
	9	20	25	40	50
½"	1 x 11 <b>1 x 17</b>	1 x 11 <b>1 x 11</b>	1 x 11 <b>1 x 11</b>	1 x 11 <b>1 x 11</b>	1 x 11 <b>1 x 11</b>
¾"	1 x 11 <b>1.1 x 17</b>	1 x 11 <b>1 x 11</b>	1 x 11 <b>1 x 11</b>	1 x 11 <b>1 x 11</b>	1 x 11 <b>1 x 11</b>
1"	1 x 17 <b>1.2 x 17</b>	1 x 11 <b>1 x 11</b>	1 x 11 <b>1 x 11</b>	1 x 11 <b>1 x 11</b>	1 x 11 <b>1 x 11</b>
1¼"	1 x 17 <b>1.2 x 17</b>	1 x 11 <b>1 x 11</b>	1 x 11 <b>1 x 11</b>	1 x 11 <b>1 x 11</b>	1 x 11 <b>1 x 11</b>
1½"	1 x 17 <b>1.3 x 17</b>	1 x 11 <b>1 x 17</b>	1 x 11 <b>1 x 11</b>	1 x 11 <b>1 x 11</b>	1 x 11 <b>1 x 11</b>
2"	1.2 x 17 <b>2 x 17</b>	1 x 11 <b>1 x 17</b>	1 x 11 <b>1 x 17</b>	1 x 11 <b>1 x 11</b>	1 x 11 <b>1 x 11</b>
2½"	1.4 x 17 -	1 x 17 <b>1 x 17</b>	1 x 11 <b>1 x 17</b>	1 x 11 <b>1 x 11</b>	1 x 11 <b>1 x 11</b>
3"	2 x 17 -	1 x 17 <b>1.2 x 17</b>	1 x 17 <b>1 x 17</b>	1 x 11 <b>1 x 17</b>	1 x 11 <b>1 x 11</b>
4"	-	1.1 x 17 <b>1.4 x 17</b>	1 x 17 <b>1.2 x 17</b>	1 x 11 <b>1 x 17</b>	1 x 11 <b>1 x 17</b>
6"	-	1.5 x 17 <b>2 x 17</b>	1.3 x 17 <b>2 x 17</b>	1 x 17 <b>1.1 x 17</b>	1 x 17 <b>1 x 17</b>
8"	-	2 x 17 -	2 x 17 -	1.1 x 17 <b>1.4 x 17</b>	1 x 17 <b>1.2 x 17</b>
10"	-	-	2 x 17 -	1.3 x 17 <b>2 x 17</b>	1.1 x 17 <b>1.4 x 17</b>

Cable length needed is pipe length multiplied by the number of cables or the spiral ratio.

## Design Guide

### STEP 2

Calculation of Heating Cable Length

$$\text{Total length required} = \text{heater length in metres (m) - from STEP 1} \\ + 0.3\text{m per power connection} \\ + 1.0\text{m per tee splice or tee power connector} \\ + 1.0\text{m per valve} \\ + 1.0\text{m per insulated pipe support} \\ + 0.3\text{m per pipe flange} \\ + \text{double traced allowance}^*$$

\* When a teed branch line is less than 2m long, it is usually more economical to double trace the short branch in a loop down and back. Therefore, add the length of each such branch in calculating total heating cable length.

### STEP 3

Determine the number of heating circuits / local distribution panel (LDP) requirements

All heating circuits must be provided with adequate over-current earth leakage protection.

- i) LDP's are provided with 230V, 16A Type C circuit breakers to BS EN 60 898 and are fitted with a suitably rated residual current device.
- ii) More than one heater segment may be connected to a circuit breaker provided that the maximum heater length does not exceed the breaker capacity.
- iii) The number of circuits will normally be determined by the piping layout.

$$\text{Minimum number of heating circuits} = \frac{\text{Total heating cable length}}{\text{Maximum heater circuit length}}$$

#### Circuit breaker vs. Maximum Cable Length (230V)

		Heating Cable Maximum Length (m)			
		11FSM2		17FSM2	
Startup Temp	0°C	-20°C	0°C	-20°C	
16A	128	124	102	88	

Note. In addition to over current protection, all heating circuits must be provided with a 30mA residual current device (rcd). A 30mA, 30ms rcd is fitted to each LDP.

Distribution panels are available with 3,6,9, or 12 circuit capacity. Select a panel having circuit capacity equal to or larger than the number of circuits.

# System Components

## STEP 4

### Determination of System Components

#### Heating Cable Product Data

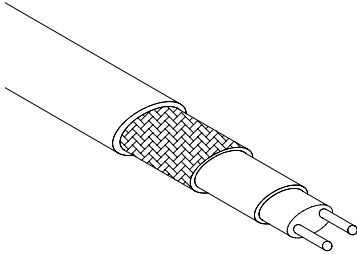

Maximum pipe temperature	Catalogue Reference	Nominal W/m @ 5°C	
		Metal Pipe	Plastic Pipe
65°C	11FSM2-CT	11	8.2
	17FSM2-CT	17	12.5

Freezstop Micro xxFSM2-CT self-regulating heating cable is designed for freeze protection of metal and plastic pipes. Heat Trace recommend braided and overjacketed heaters for all applications. Plastic pipes must be foiled over the heater run.

Operating Voltage	208 - 277V	
Power output multiplier factor	11FSM	17FSM
208V	0.86	0.89
220V	0.94	0.95
230V	1.00	1.00
240V	1.06	1.05
277V	1.30	1.24
Nominal dimensions	5.6 x 7.9 mm	
Minimum bending radius (20°C)	20mm	

#### UNI-CLIP Micro termination and connection system

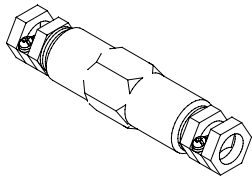

MICRO UNI-CLIP is a universal power termination and splicing system. It has been developed for simple connection of Freezstop Micro self-regulating heating cables. Termination is easy without the need for special tools.

A single MICRO UNI-CLIP connector may be used for:-

- Power connection to one or two heating cables, (max: 2.5mm<sup>2</sup>).
- In-line splicing of two heating cables,
- Tee-splicing of three heating cables
- Cross splicing of 4 heating cables

**Catalogue Ref: UC/M**  
MICRO UNI-CLIP Connector  
(rating 16A, 230V, 2.5mm<sup>2</sup>)

**Number required:**  
1 per power connection  
1 per in-line splice  
1 per tee or cross splice

Each Micro UNI-CLIP is supplied complete with all components needed for all of the above termination methods.

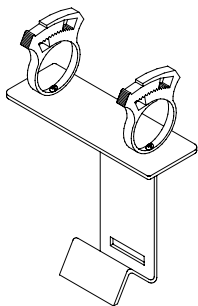

**Catalogue Ref : PB/UCM**  
MICRO UNI-CLIP Pipe Mounting Bracket

MICRO UNI-CLIP is normally fitted to a PB/UCM mounting bracket. This positions the connector outside the thermal insulation for accessibility.

**Number required:**  
1 per MICRO UNI-CLIP

## System Components

### Pipe Fixing Straps

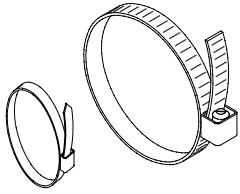

Catalogue Ref : PFSxxx or NT/SF

The PB/UCM is fitted to pipework up to 50mm bore with cable ties provided with the PB/UCM. For larger pipes, pipe fixing straps are required as follows.

PFS050 for pipes  $\leq$  125mm diameter  
PFS100 for pipes  $\leq$  250mm diameter

**Number required:**  
1 per PB/UCM

### PVC Fixing Tape

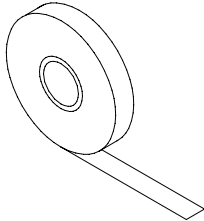

Catalogue Ref : FT/HTP

Fixing tape is used to hold the Freezstop Micro heating cable in position on metal pipes.

Number required: FT/HTP rolls per 100m of pipework

Nominal Bore of Pipe	ins. mm	1/2 15	1 25	1.5 40	2 50	3 75	4 100	6 150	8 200
Straight Traced	rolls	2	3	4	5	7	10	15	20
Spiraled	rolls	1	1	1	2	2	2	3	4

### Aluminium Fixing Tape

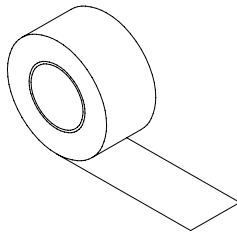

Catalogue Ref : FT/ALUM

Fixing tape is fitted over Freezstop Micro heating cable on plastic pipes

**Number required:**  
1 roll per 45m of heating tape

### Lagging Entry Kit

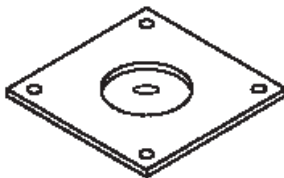

Catalogue Ref : LEK/U

For exiting the Freezstop Micro heating cable from the thermal insulation. Used for outdoor installations, for sealing cable exit points to prevent rain ingress.

**Number required:**  
1 per cable exit at tees, power connection, etc.

### Caution Labels



Catalogue Ref : CL

'Electric Heat Traced' warning label for fixing at 6m intervals to the outside of the insulation cladding.

**Number required:**  
1 label every 6m of traced pipework

### End Seal

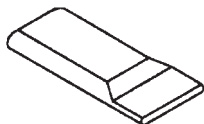

Catalogue Ref : BES1

Silicone rubber end seal for sealing the remote ends of the heating tape.

**Number required:**  
1 per cable end

### End Seal Adhesive

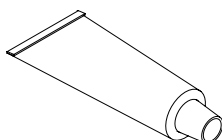

Catalogue Ref : RTV0.5

For fixing end seal BES1 to end of heating cable.

**Number required:**  
1 per 5 end seals

## System Components

---

### Temperature Control

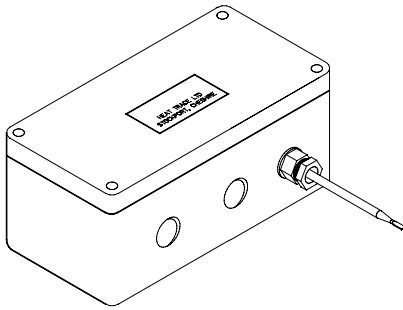
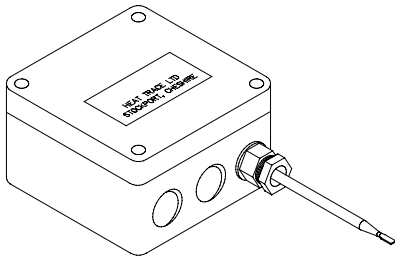

Freezstop Micro can be operated uncontrolled and due to its self regulating properties will provide a reduced output in warmer months. However, except for very small installations, it is prudent to fit a seasonal thermostat for reasons of energy efficiency which will energise the freeze protection system only when the ambient temperature approaches freezing point.

Only one thermostat is needed per Freezstop Micro system. The type is selected according to the number of circuits in the system:

- Type AT-A, for a single circuit or multiple circuits whose start up load does not exceed 16A single phase (240V)
- Type AT-A/C1, for up to 6 circuits (or more if the start up load does not exceed 32A on each of 3 phases. AT-A/C1 comprises a plastic enclosure 190 x 150 x 85mm incorporating thermostat, with control fuse, contactor, heating 'on' indication and terminals. Used in conjunction with LDP
- Type AT-A/C2, for up to 12 circuits. The start up load should not exceed 63A on each of 3 phases. AT-A/C2 comprises a plastic enclosure 190 x 150 x 85mm incorporating thermostat, with control fuse, contactor, heating 'on' indication and terminals. Used in conjunction with LDP

**Number required:**

1 per Freezstop Micro System

---

### Marshalling Junction Box

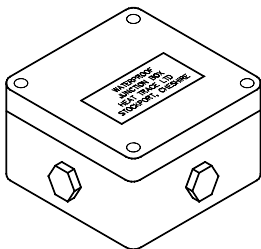

Catalogue Ref : WJB/16  
(rating 32A, 230V, 6mm<sup>2</sup>)

Marshalling boxes may be needed when feeding to multiple MICRO-UNICLIP power connectors, or rating - A 230V, where long hook-up distances result in cable sizes larger than 2.5mm<sup>2</sup>. Enclosure provided undrilled. Dims: 103 x 103 x 65mm

**Number required:**

To be determined according to circuit arrangement

---

### Local Distribution Panel (LDP)

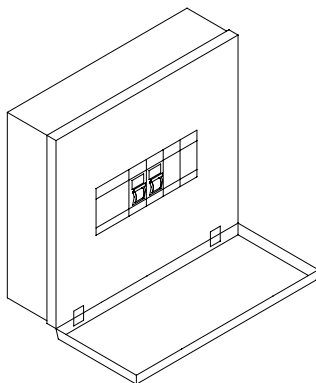

The distribution panel is selected according to the number of circuits calculated at STEP 3. Each panel is provided with a 16A circuit breaker for each outgoing circuit. A ground fault protection device is fitted, sensitivity 30mA, 30ms for protection of all circuits. The LDP is also provided with a main incoming isolator. Standard panels are:

- LDP-03 for up to 3 x 16A, 230V circuits, single phase incoming feed.
- LDP-06 for up to 6 x 16A, 230V circuits, 3 phase & neutral incoming feed.
- LDP-09 for up to 9 x 16A, 230V circuits, 3 phase & neutral incoming feed.
- LDP-12 for up to 12 x 16A, 230V circuits, 3 phase & neutral incoming feed.

The LDP is rated IP54 for internal use. It should therefore be suitably weather protected if installed outdoors.

**Number required:**

1 per system of up to 12 circuits

---

# Installation

---

## Typical Freezstop Micro System Installation

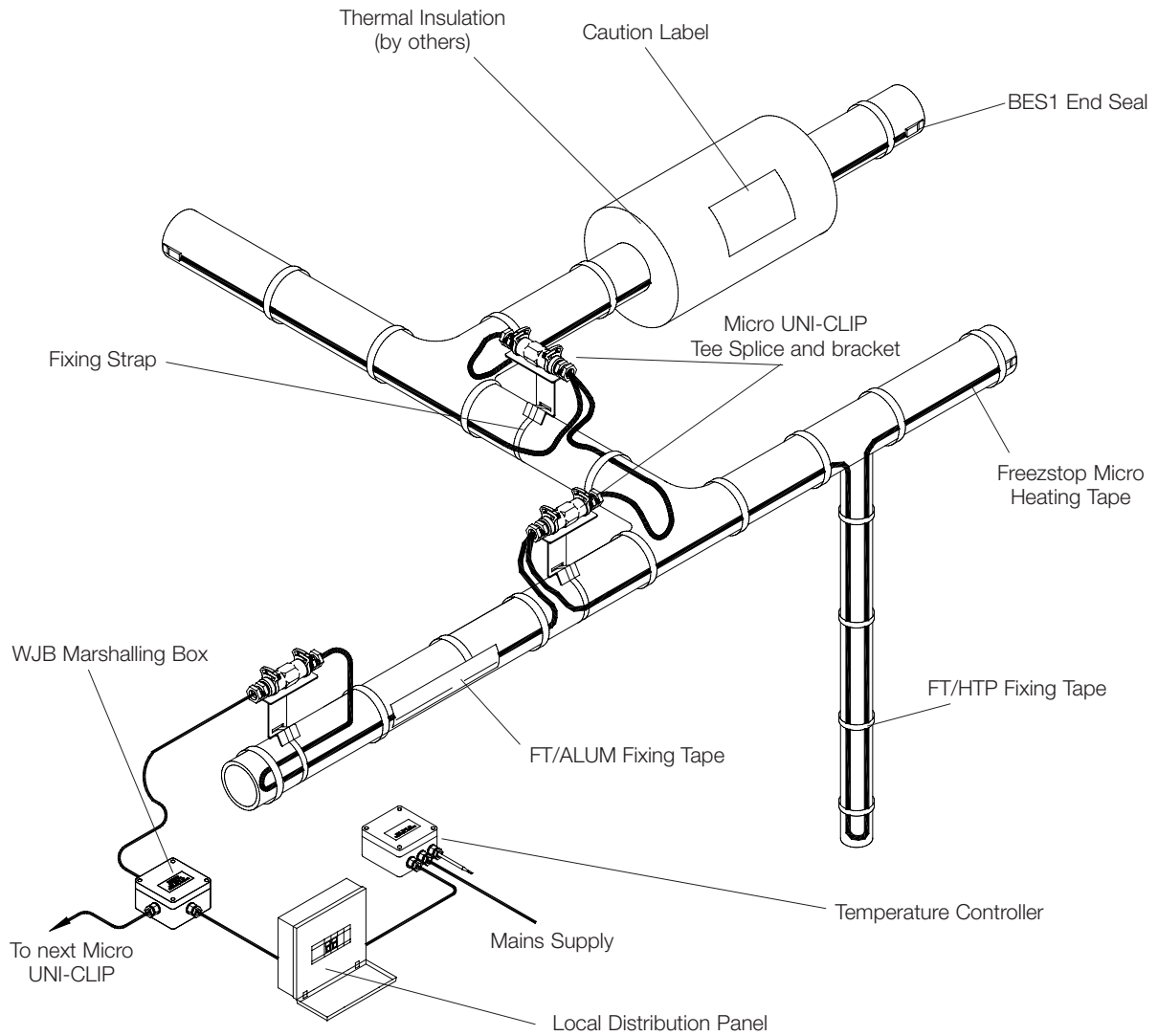

# Typical Wiring Arrangement Schematic

## 4 Way 240VAC 63A Distribution Board

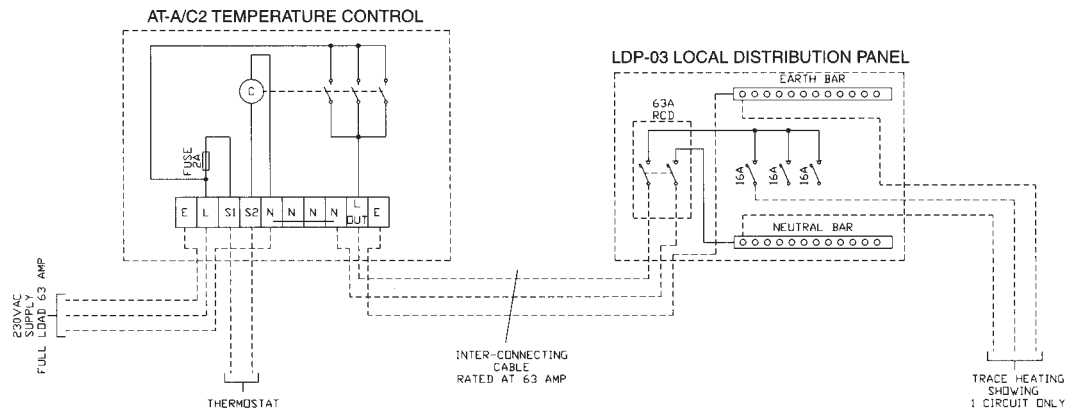

## 12 Way 415VAC 63A Distribution Board

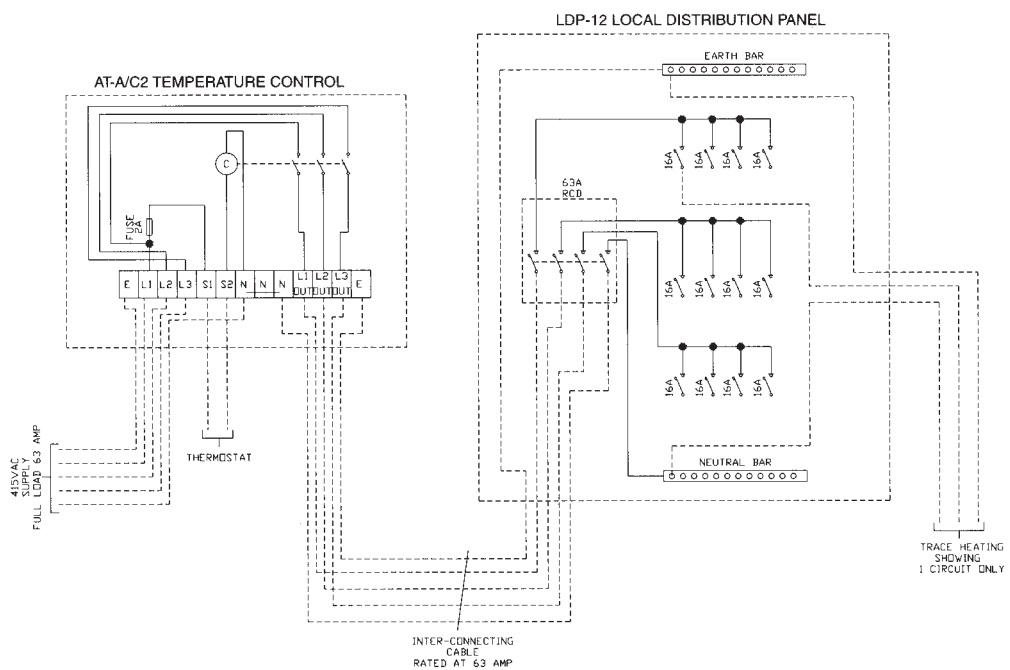

# Bill of Materials - Order Form

**CUSTOMER NAME AND ADDRESS:**

\_\_\_\_\_  
 \_\_\_\_\_  
 \_\_\_\_\_  
 \_\_\_\_\_  
 \_\_\_\_\_  
 Contact: \_\_\_\_\_  
 Tel: \_\_\_\_\_  
 Fax: \_\_\_\_\_  
 Order Number \_\_\_\_\_  
 Order Date    /    /        Date Required    /    /

**SUPPLIER DETAILS:**

Heat Trace Limited  
 Tracer House, Cromwell Road,  
 Bredbury, Stockport  
 Cheshire, SK6 2RF  
 England  
 \_\_\_\_\_  
 Contact: Sales Department  
 Tel:        +44 (0)161 430 8333  
 Fax:        +44 (0)161 430 8654  
 \_\_\_\_\_  
 \_\_\_\_\_

QUANTITY	TYPE REF.	DESCRIPTION	UNIT PRICE	EXTENDED
m	11FSM2-CT	Freezstop Micro Self Regulating Heating Tape.	_____	_____
m	17FSM2-CT	Freezstop Micro Self Regulating Heating Tape.	_____	_____
pcs	UC/M	Uniclip Micro Connector.	_____	_____
pcs	PB/UCM	Uniclip Micro Pipe Mounting Bracket.	_____	_____
pcs	NT/SF	Nylon Ties	_____	_____
pcs	PFS _ _ _ _	Pipe Fixing Straps.	_____	_____
pcs	FT/HTP	PVC Fixing Tape.	_____	_____
pcs	FT/ALUM	Aluminium Fixing Tape.	_____	_____
pcs	LEK/U	Lagging Entry Kit.	_____	_____
pcs	CL	Caution Labels.	_____	_____
pcs	BES1	End Seal.	_____	_____
pcs	RTV0.5	End Seal Adhesive.	_____	_____
ea	AT-A	Air sensing thermostat, 16A single phase max.	_____	_____
ea	AT-A/C1	Air sensing thermostat, 32A 3 phase max.	_____	_____
ea	AT-A/C2	Air sensing thermostat, 63A 3 phase max.	_____	_____
ea	LDP-03	3 x 16A circuits, single phase incoming feed.	_____	_____
ea	LDP-06	6 x 16A circuits, 3 phase & neutral incoming feed.	_____	_____
ea	LDP-09	9 x 16A circuits, 3 phase & neutral incoming feed.	_____	_____
ea	LDP-12	12 x 16A circuits, 3 phase & neutral incoming feed.	_____	_____
ea	WJB/16	Marshalling Junction Box	_____	_____
			SUBTOTAL	£ _____
			C & P	£ _____
			VAT	£ _____
			TOTAL PRICE	£ _____

Additional materials needed to complete the heat tracing installation:

- All mains and interconnecting cables/glands
- Thermal Insulation

Fax this order form to our head office on +44(0)161-430 8654



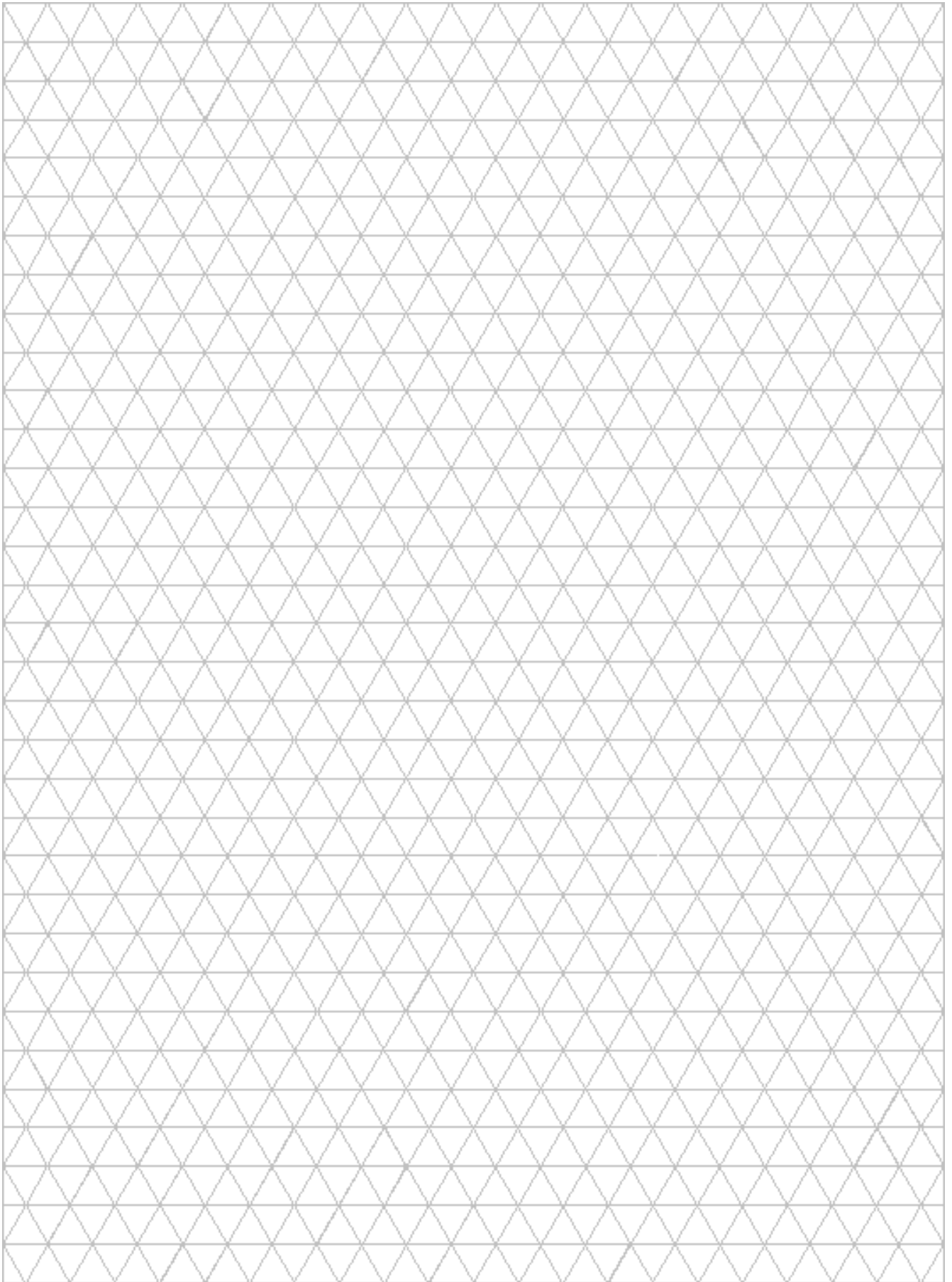

## **HEAT TRACE LTD**

Mere's Edge, Chester Road, Helsby, Frodsham, Cheshire, WA6 0DJ, UK.  
Tel: +44 (0)1928 726 451 Fax: +44 (0)1928 727 846 [www.heat-trace.com](http://www.heat-trace.com)

---

The information given herein, including drawings, illustrations and schematics (which are intended for illustration purposes only), is believed to be reliable. However, Heat Trace Ltd makes no warranties as to its accuracy or completeness and disclaims any liability in connection with its use. Users of Heat Trace Ltd products should make their own evaluation to determine the suitability of each such product for specific applications. In no way will Heat Trace Ltd be liable for any damages arising out of the misuse, resale or use of the product.

---